

PROCEDURES OF CALIBRATION AFTER REPLACING AUTO TILT BUCKET

Perform "Auto Tilt Bucket Exchange" calibration when replacing the bucket to the auto tilt bucket. This is not applicable for the rotational bucket.

Perform this calibration on the steady ground so that machine does not incline when the bucket is operated.

Check there is no person in the operating range of work equipment, and pay great attention to the safety when moving the work equipment.

Perform this calibration under the following conditions.

- Working mode: ATT/P mode
- Fuel control dial: High idle (MAX) position
- Auto-deceleration: Canceled

METHOD FOR STARTING APPLICATION FOR CALIBRATION AFTER REPLACING AUTO TILT BUCKET

1. Tap "Menu button" of the control box.
Main menu screen is displayed.



2. Tap Machine Setup button.
The screen changes to Machine Setup screen.

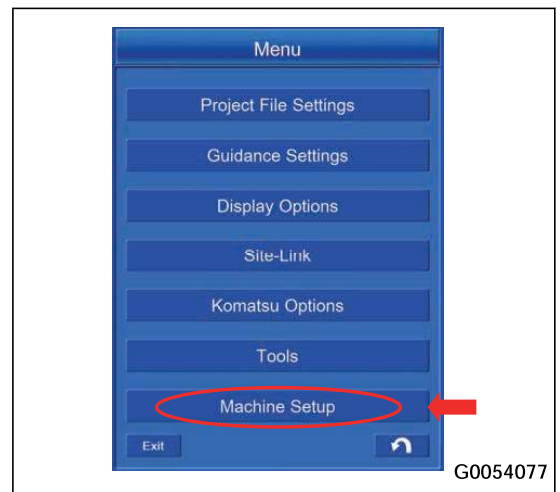

- 3. Tap Bucket Exchange button.
The screen changes to Bucket Exchange screen.

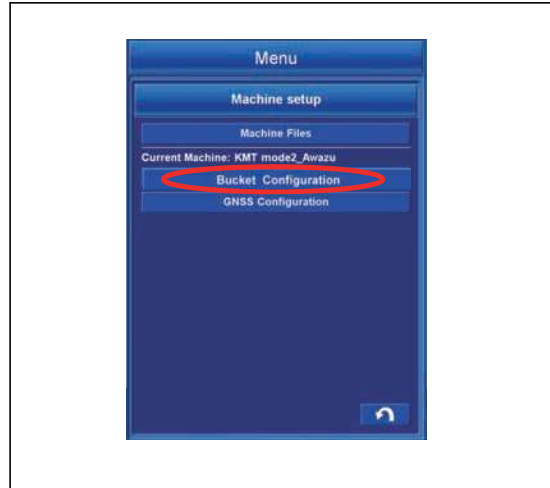

- 4. Tap Bucket Exchange button.
The screen changes to "Bucket Exchange" screen.

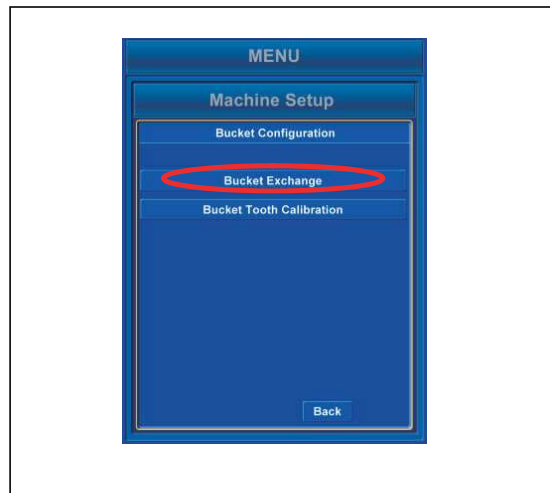

- 5. Tap Auto Tilt Bucket(IMU) button.
"Auto Tilt Bucket Exchange" calibration starts and the screen changes to the bucket file select screen.



G0088728

METHOD FOR SELECTING AUTO TILT BUCKET FILES

1. Select the bucket file of the bucket to be used from the list on the Conventional Bucket Files screen.
 - To change the content of the selected bucket file, tap “Edit” button.
 - When you do not change, tap the ENTER button.

REMARK

- The currently selected bucket is highlighted in yellow.
- When you use the file which exists, tap the ENTER button.
- If the bucket file is not in the list, tap “New” button to make a new file. The entered data is saved in the file.

Function of each button in the screen is as follows.

- “New” button
It makes a new file based on the highlighted file.
- “Rename” button
It changes the name of the highlighted file.
- “Copy” button
It copies the bucket file from the USB flash drive into the control box.
- “Delete” button
It deletes the highlighted file.
- “RETURN” button
The screen goes back to the previous screen.

2. When you complete the setting, turn the starting switch key to the OFF position, turn it to the ON position again, and restart the control box.

When you use the file which exists, tap “ENTER” button. When you select “ENTER” or “Edit” button, the screen changes to the next screen and the tilt bucket sensor is automatically turned off.

Replace the bucket during this time. When the bucket exchange is completed, push “Next” button to reconnect to the tilt bucket sensor.

After this message, if you push the CANCEL button without replacement of the bucket, a message to reconnect to the tilt bucket sensor will be shown.

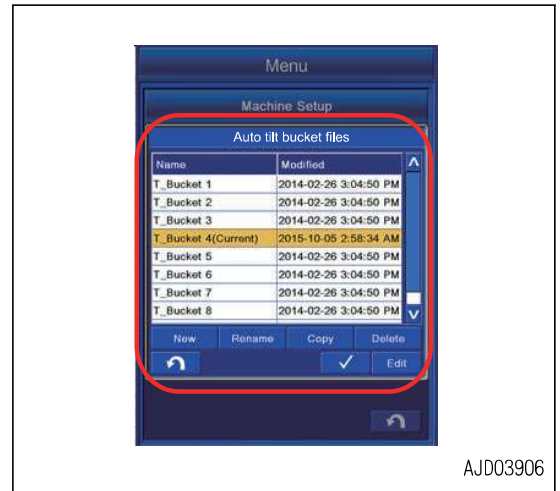

Reconnect to the tilt bucket sensor. Be careful that the precision of the sensor can decrease if you move the bucket at this time. When the tilt sensor is recognized, the screen automatically changes to the next screen.



If you cannot connect to the tilt bucket sensor within 20 seconds, the message that follows will be shown. Push "ENTER" button, and the screen goes back to the previous screen.

If you cannot connect after you try it again, consult your Komatsu distributor.

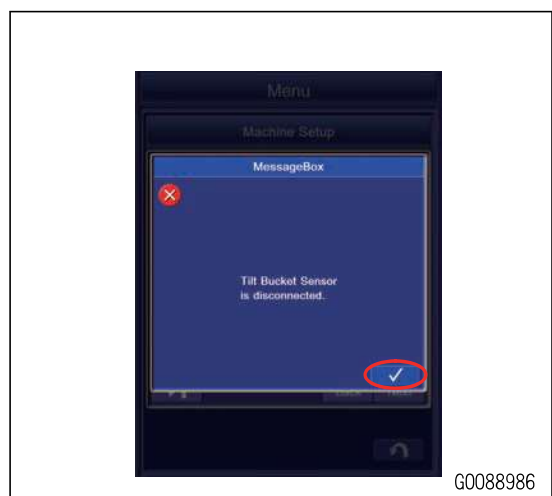

Select the installation direction of the tilt sensor from the pull-down menu (1). Set the tilt sensor label and direction of connector.

Select the tilt sensor label and connector orientation as viewed from inside the operator cab from the 24 patterns below.

Check them with the tilt axis in the horizontal condition.

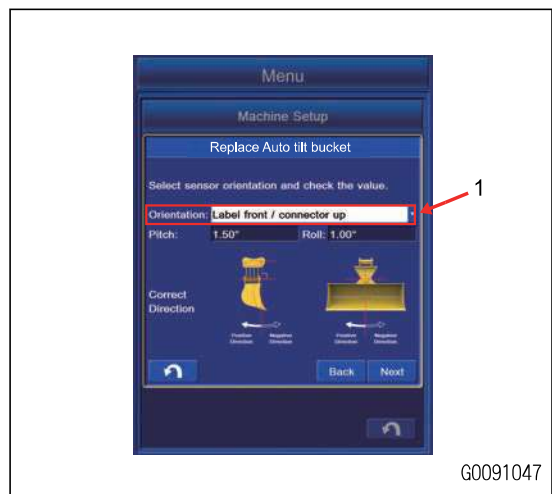

The names for each orientation are as shown in the figure below.

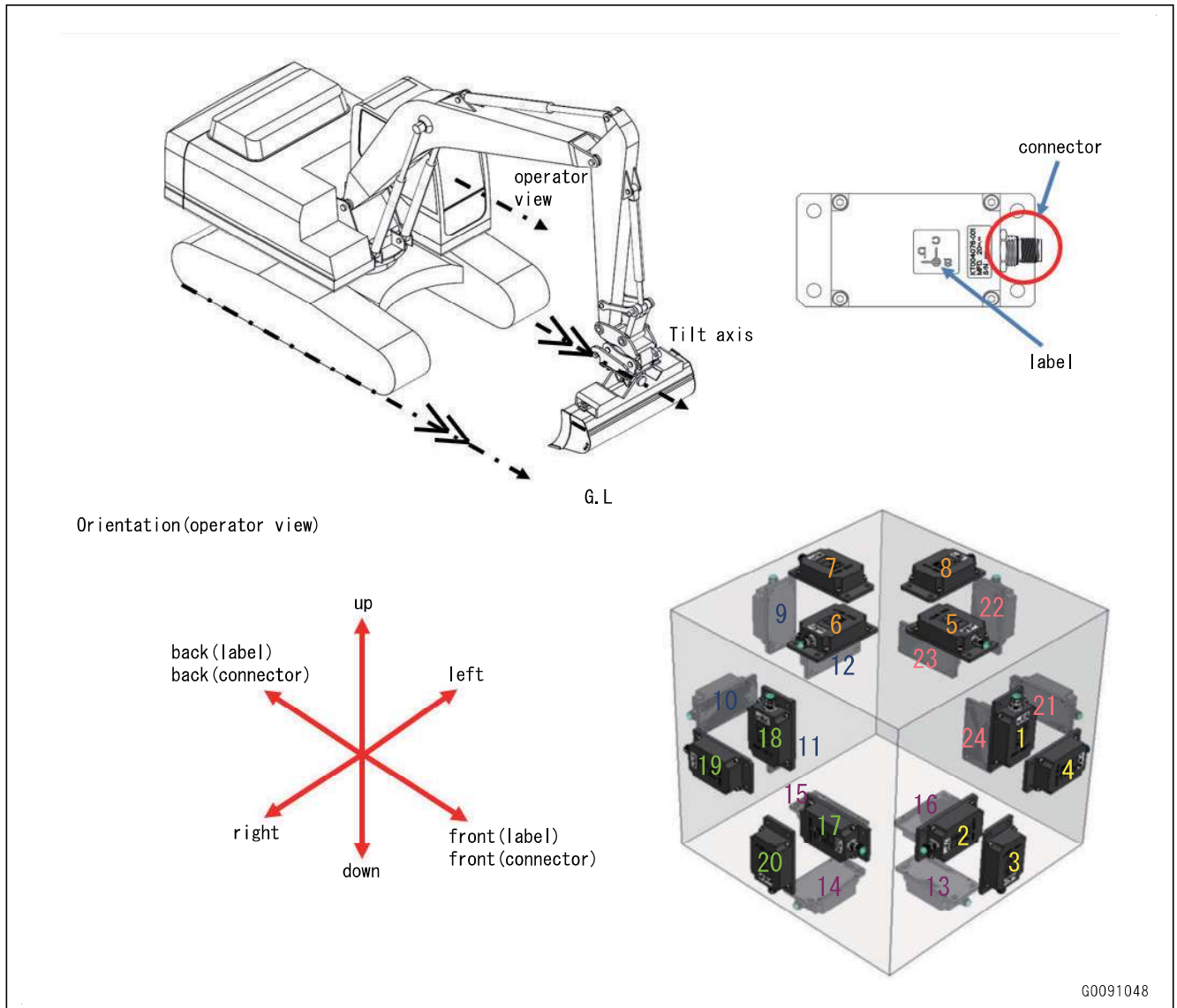

No.	Orientation	No.	Orientation
1	Label front / connector up	13	Label down / connector forward
2	Label front / connector right	14	Label down / connector right
3	Label front / connector down	15	Label down / connector backward
4	Label front / connector left	16	Label down / connector left
5	Label up / connector forward	17	Label right / connector forward
6	Label up / connector right	18	Label right / connector up
7	Label up / connector backward	19	Label right / connector backward
8	Label up / connector left	20	Label right / connector down
9	Label back / connector up	21	Label left / connector forward
10	Label back / connector right	22	Label left / connector up
11	Label back / connector down	23	Label left / connector backward
12	Label back / connector left	24	Label left / connector down

For the installation method as shown in the figure below, select "Label Front, Connector Left" from the pull down menu (1).

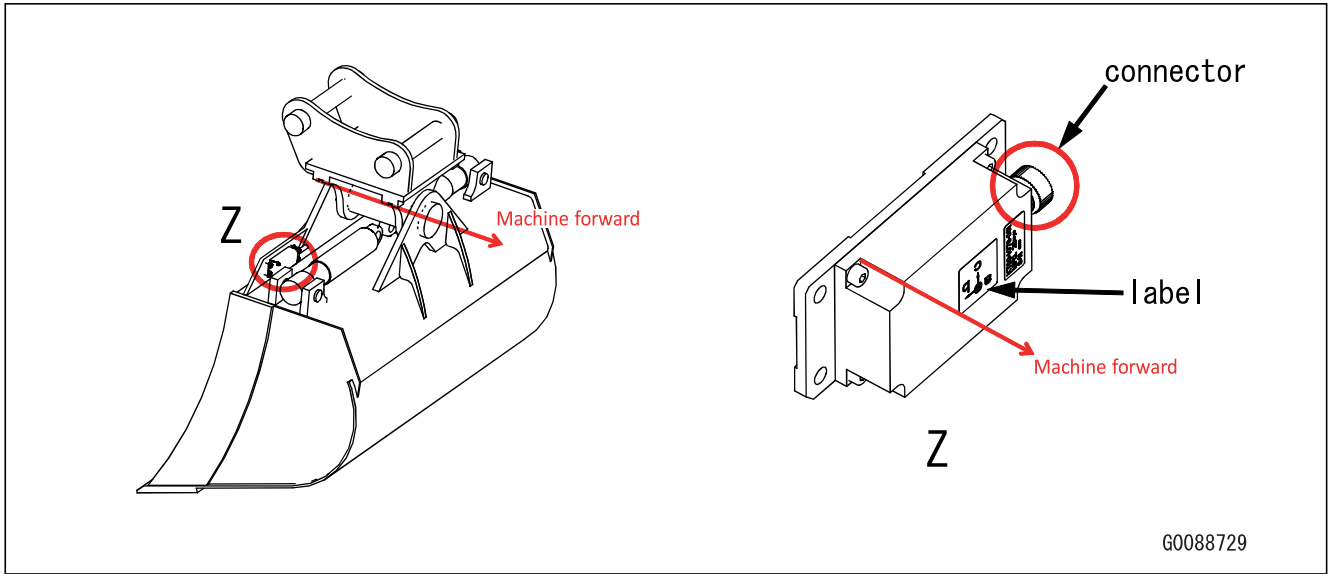

G0088729

After you selected, continue to move the bucket back and forth and in a tilting direction, for 1 second or more in each direction. Make sure that the value (2) for the pitch angle increases when the bucket DUMP operation is done (in the "+positive" direction shown in the figure). Also make sure that the value (3) for the roll angle increases when the tilt operation is done in the clockwise direction (in the "positive" direction shown in the figure). After you selected and checked the value, tap "Next" button (4).

REMARK

"Next" button (4) is grayed out at first, and it becomes available when the rotation direction of the tilt bucket is recognized. If the button keeps grayed out, carefully do the tilt operation in clockwise and counterclockwise, for 1 second or more in each direction again.

If you selected "ENTER" button on the selection screen of bucket file, do the procedure of auto calibration calculation and input of parameter value.

If you selected "Edit" button, the screen changes to the bucket information input screen.



G0091049



G0088988

PREPARATIONS FOR MEASURING AUTO TILT BUCKET SHAPE

1. Install the digital angle gauge as shown in figure (1), and adjust the tilt axis until it becomes horizontal.

REMARK

Make the inclination angle of the tilt bucket almost horizontal by tilt operation, and then adjust the tilt axis to be horizontal by bucket operation.

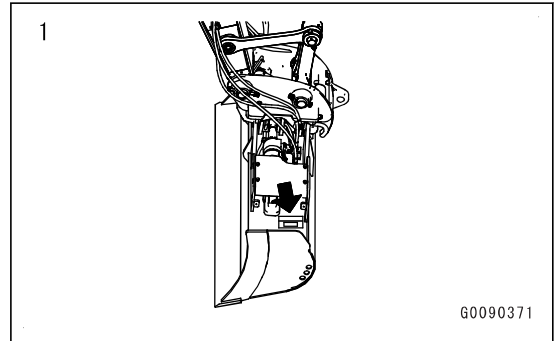

2. Install the digital angle gauge as shown in figure (2).
3. After the installation is completed, do the tilt operation slowly until the inclination angle of the tilt bucket aligns with "Roll Angle" shown in the figure. (Lever stroke: 50 % or below)

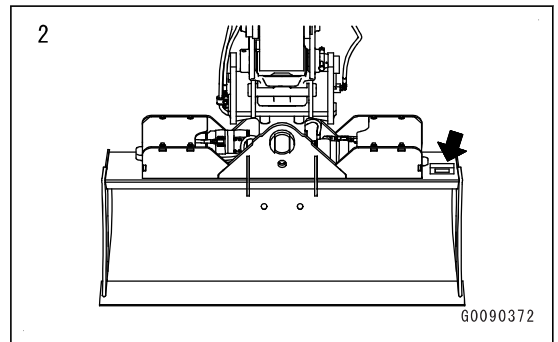

4. When the operation is completed, tap "Next" button.

REMARK

- The measurement preparation specified here is for adjustment of the inclination angle of the auto tilt bucket.
- If you use the digital angle gauge that shows positive value when the tilt operation is done counterclockwise from the cab side, read it as a positive value in clockwise tilt operation and as a negative value in counterclockwise tilt operation.
- After the adjustment is completed, operate the bucket. There is no problem if the tilt axis is not horizontal.
- Do not do the tilt operation until the measurement of an auto tilt bucket shape is completed.
- Use the digital angle gauge with precision of $\pm 0.2^\circ$ or below.
- Be sure to calibrate the digital angle gauge before use.



METHOD FOR MEASURING AUTO TILT BUCKET SHAPE

Measure the dimensions and angles for inputting the bucket information.

Measure the length dimension to mm unit, and angle to 0.1 ° unit.

1. Measure the dimension (1).

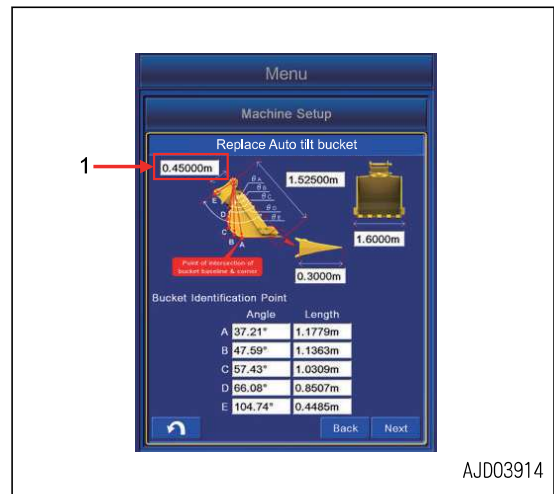

Dimension (1) is the distance between the bucket pin (7) and the bucket link pin (8).

Measure with a tape measure, and input the data.

(F): When the quick coupler is not installed

(G): When the quick coupler is installed

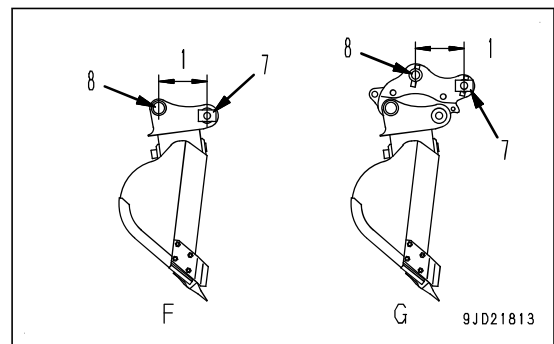

2. Measure the dimension (2).

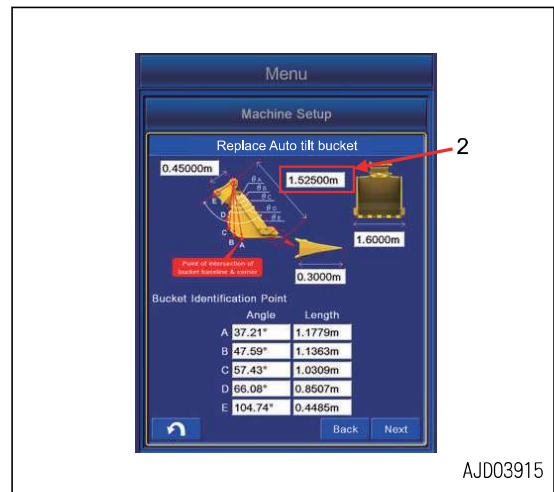

Dimension (2) is the distance between the bucket pin (7) and tooth tip.

Measure with a tape measure, and input the data.

(F): When the quick coupler is not installed

(G): When the quick coupler is installed

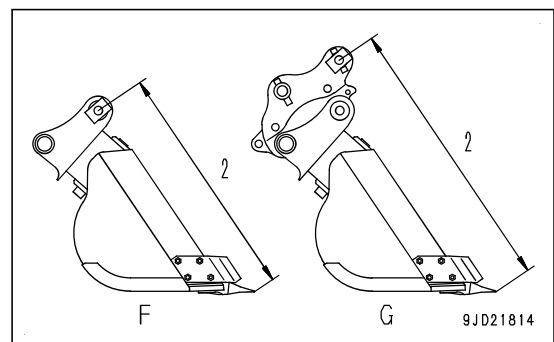

3. Measure the dimension (3).

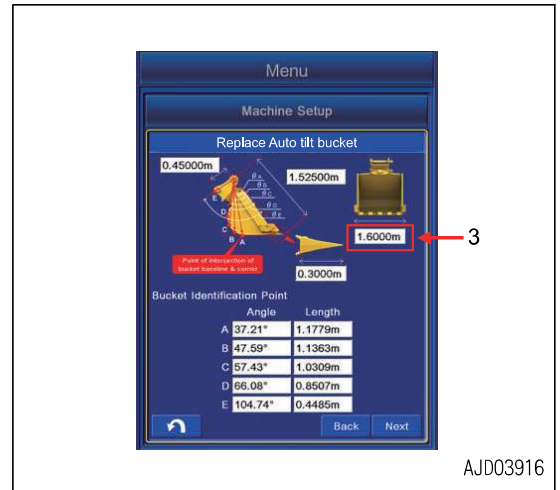

AJD03916

Dimension (3) is the distance between the bottom of bucket side cutters.

Measure with a tape measure, and input the data.

Measure the distance at widest part and input the data if the bucket has no side cutters.

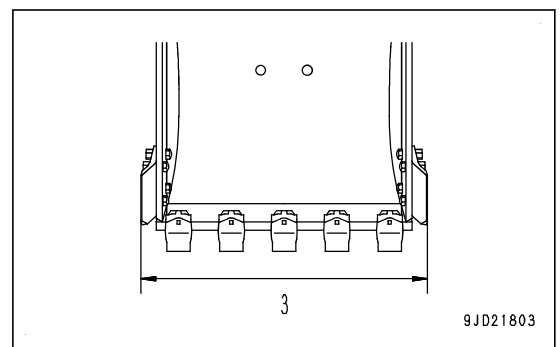

9JD21803

4. Measure the dimension (4).

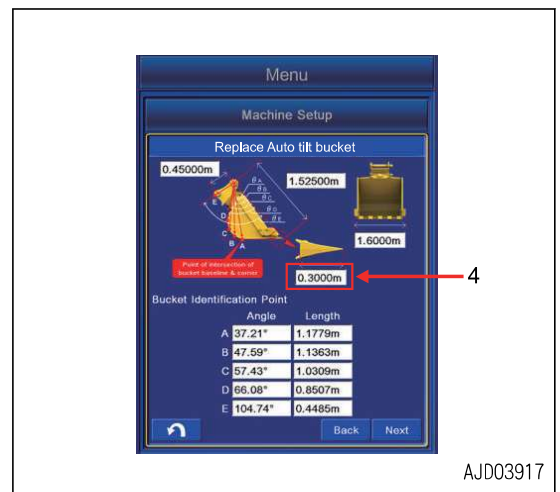

AJD03917

Dimension (4) is the distance between root and tip of the tooth.

Measure with a tape measure, and input the data.

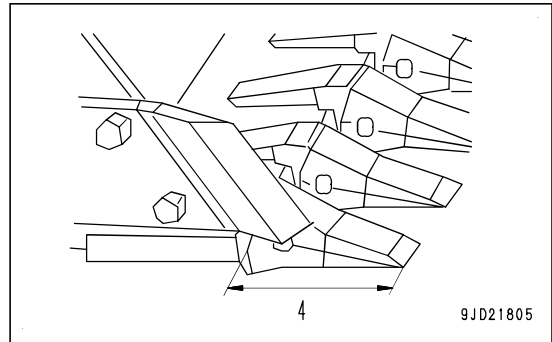
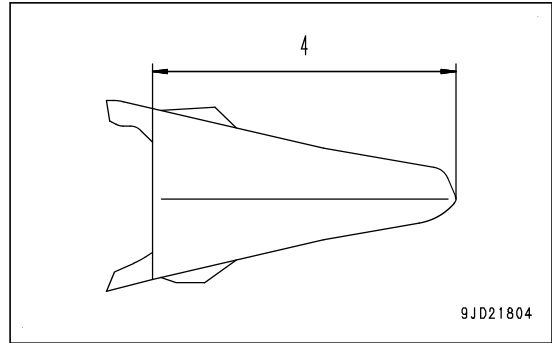

Measure the blade width (9) and input the data if bucket has no tooth.

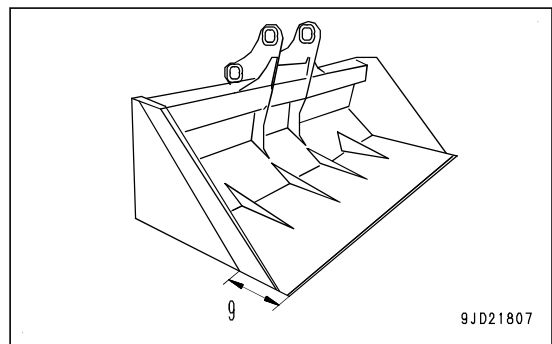
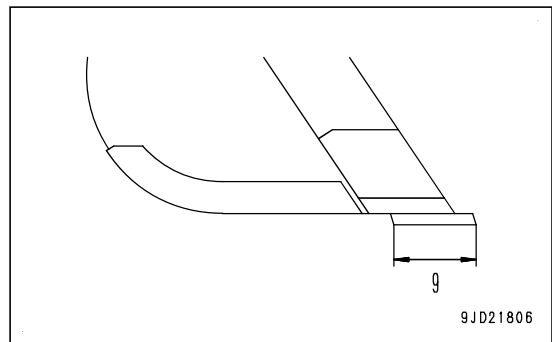

5. Measure the angle (5) and dimension (6) of Bucket Identification Point.

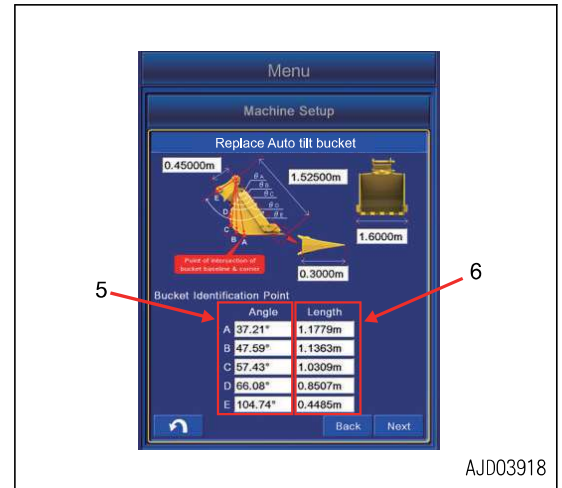

AJD03918

6. Put the mark with marker pen at the 5 points (A) to (E) of Bucket Identification Point.
7. Bucket Identification Point (A) is the cross point of straight line of bucket bottom face and corner.

If it is difficult to distinguish the straight line of bottom face and corner, select the point that touches the ground if the floor face digging were performed.

Bucket Identification Point (E) is the most outside part on the extended line between bucket pin and bucket link pin.

Bucket Identification Point (B), (C), and (D) divide equally the distance between (A) and (E).

8. Set the magnet pole jig (10) to the bucket pin. Align the center of foot pin and center of pole.
 (F): When the quick coupler is not installed
 (G): When the quick coupler is installed
 (H): When slope finishing bucket is installed

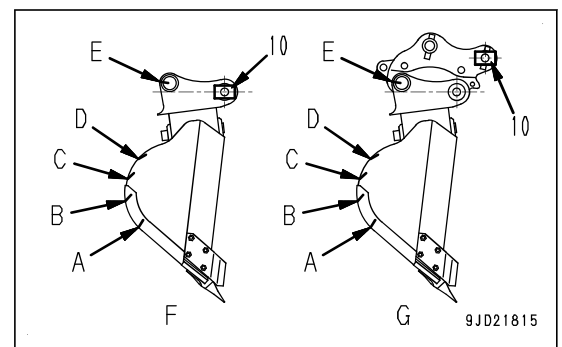

9JD21815

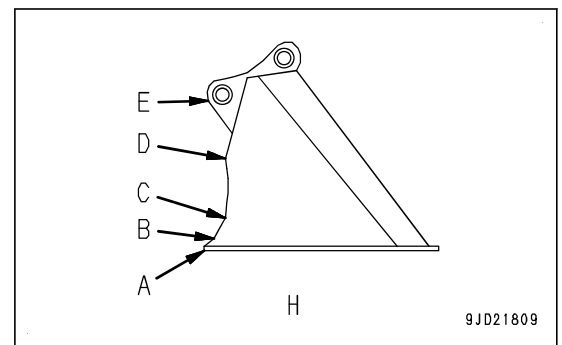

9JD21809

9. Apply the plumb (11) to the magnet pole jig (10), and set the bucket so that the line between bucket pin and tooth tip is vertical.
10. Measure the distance between the point out of (A) to (E) and center of pole with a tape measure, and input the data in the dimension column (6).
11. Put the end of string to the magnet pole (10) and stretch the string to the point out of (A) to (E).
12. Set the digital angle gauge (12) on to the string, and measure the angle (13) of (A) to (E).

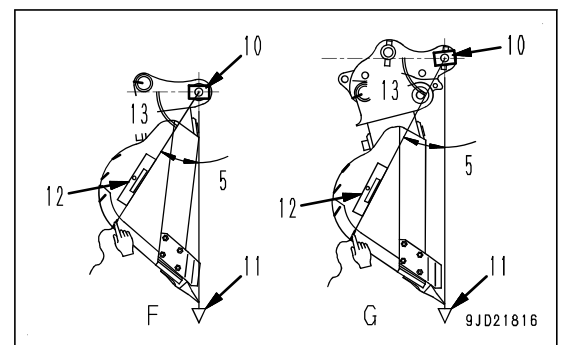

9JD21816

Angle (13) is the angle between level line of bucket pin and each point of (A) to (E).

- When the string is below the level line of bucket pin
Input the value which is subtracted the angle (13) from 90 ° in the angle (5) of Bucket Identification Point.
- When the string is above the level line of bucket pin
Input the value which is added the angle (13) to 90 ° in the angle (5) of Bucket Identification Point.

(F): When the quick coupler is not installed

(G): When the quick coupler is installed

REMARK

- 2 persons are required to measure the dimensions (6) and the Angle (5) of Bucket Identification Point.
- The work equipment is lowered due to hydraulic drift when it is above the ground. Perform measuring of Bucket Identification Point as making sure that the plumb (11) is vertical from time to time.

METHOD FOR INPUTTING BUCKET INFORMATION (AUTO TILT BUCKET)

Input the measured dimensions and angles.

Tap the inside of the white frame of dimension value to be input again, and then the numeric keypad pops up. Input the numeric value with it.

Measure the length dimension to mm unit, and angle to 0.1 ° unit.

You can input the numeric value within the range shown below.

- Numeric value (1)
Min: 0.00001 m to Max: 19.99999 m
- Numeric value (2)
Min: 0.00001 m to Max: 19.99999 m
- Numeric value (3)
Min: 0.0001 m to Max: 5.9999 m
- Numeric value (4)
Min: 0.0001 m to Max: 2.9999 m
- Angle (5)
Min: 0.01 ° to Max: 179.99 °
- Numeric value (6)
Min: 0.0001 m to Max: 5.9999 m

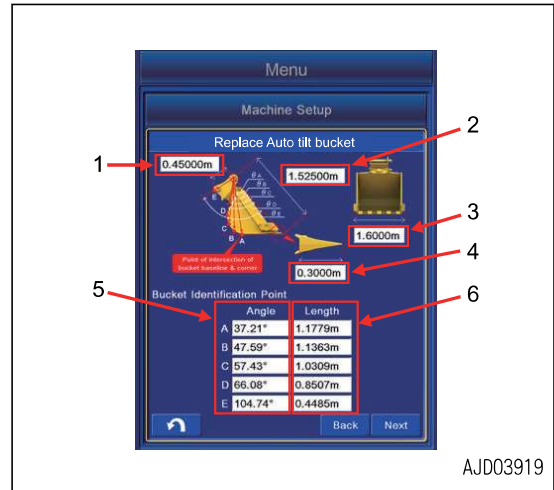

AJD03919

Check the input numeric value. If there is no problem, tap Next button.

If any numeric value or angle column is empty, even if Next button is pressed, it is invalid.

METHOD FOR MEASURING BUCKET FOOT ANGLE AND TILT WIDTH ANGLE (AUTO TILT BUCKET)

1. Use a level gauge or laser level to set the tilt axis (1) horizontally as written in "PREPARATIONS FOR MEASURING AUTO TILT BUCKET SHAPE".

(A): When the quick coupler is not installed

(B): When the quick coupler is installed

2. Tap "Bucket Angle" button.

A check mark is put in the check box of "Bucket Angle Read", and work equipment angle at that posture is saved.

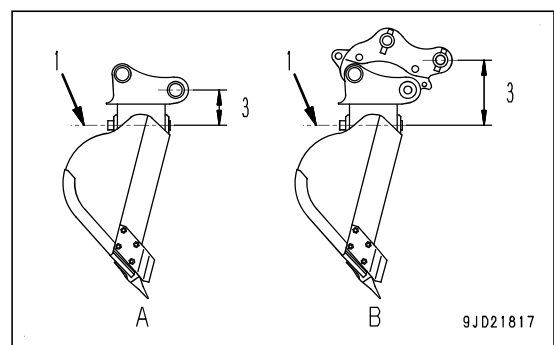

9JD21817

3. Measure the dimension (A).

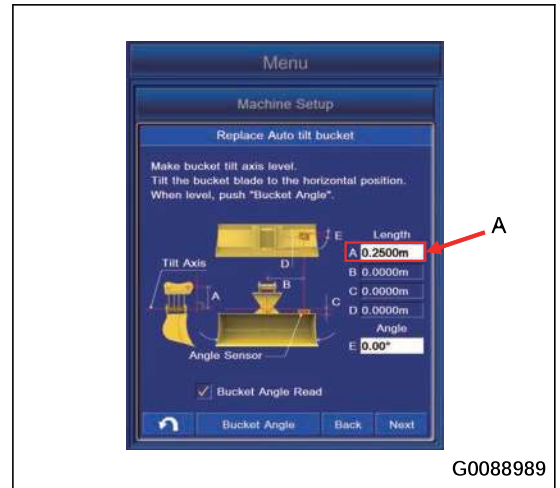

4. The dimension (A) is the vertical distance (3) between the bucket pin and the tilt axis. Use a tape measure and plumb or laser level for the measurement.

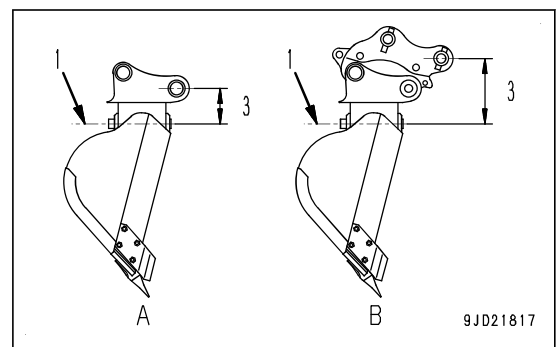

5. Measure the dimension (E).

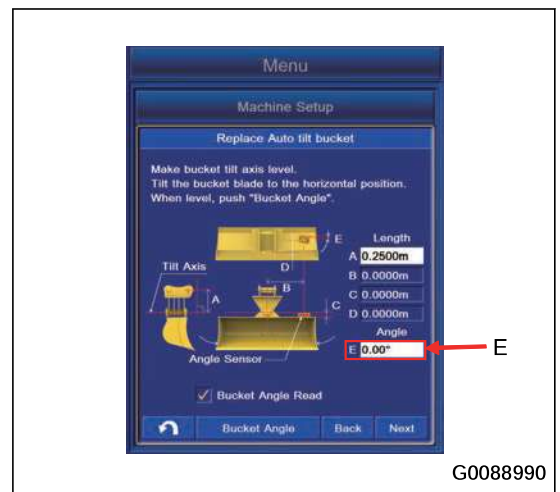

6. For the angle (E), measure the inclination angle from the axis parallel to the IMU arm top pin. The angle (E) in the cases that follow is a positive value.

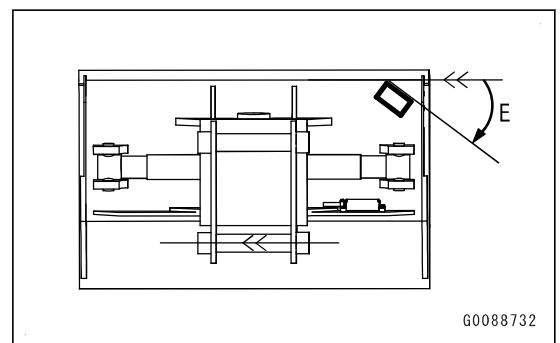

The angle (E) in the cases that follow is a negative value.

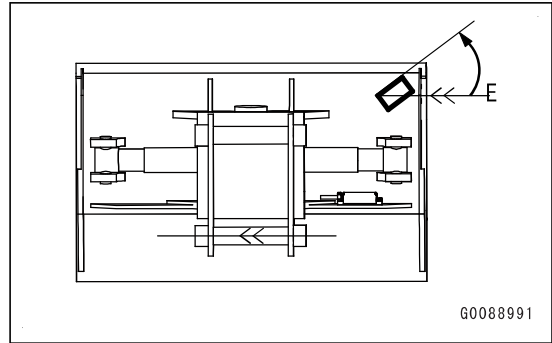

7. Input method of bucket information (auto tilt bucket)

Enter the measured dimensions and angles. Tap within the white frame of dimension value to enter again, and then the numeric keypad pops up. Input the numeric value with it. Measure the length dimension to mm unit, and angle to 0.1° unit. You can enter the numeric value within the range shown below.

- Numeric value (A)
Min: 0.00001m to Max: 5.99999m
- Numeric value (E)
Min: -90° to Max: +90°



8. Install the digital angle gauge as shown in the figure (1), and adjust the tilt axis until it becomes horizontal.

REMARK

Make the inclination angle of the tilt bucket almost horizontal by tilt operation, and then adjust the tilt axis to be horizontal by bucket operation.

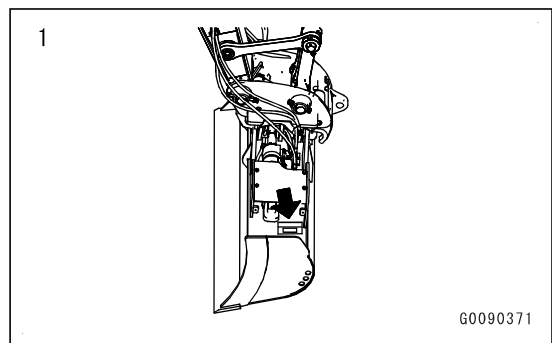

9. Install the digital angle gauge as shown in the figure (2), and do the tilt operation slowly until the inclination angle of the tilt bucket becomes 0°.

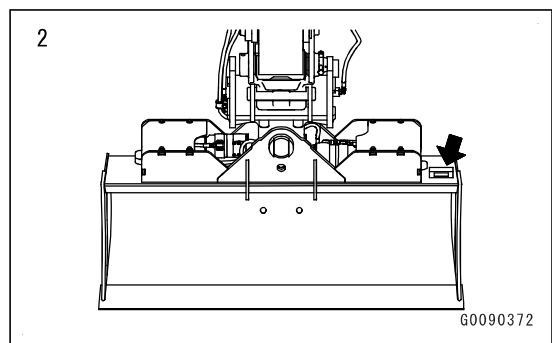

- Tap "Bucket Angle" button.

A check mark is put in the check box of "Bucket Angle Read", and work equipment angle at that posture is saved.

Check the entered numeric value. If there is no problem, tap "Next" button.

If a numeric value column is empty, even if you push "Next" button, it is disabled.



- Use a level gauge or a laser level to set the bucket pin (4) and the bucket link pin (5) horizontally.

Move the bucket only. Do not move the other work equipment (boom, arm) at this time. Also, do not move the bucket in the tilt direction (clockwise or counterclockwise when the bucket is viewed from the operator cab).

(A): When the quick coupler is not installed

(B): When the quick coupler is installed

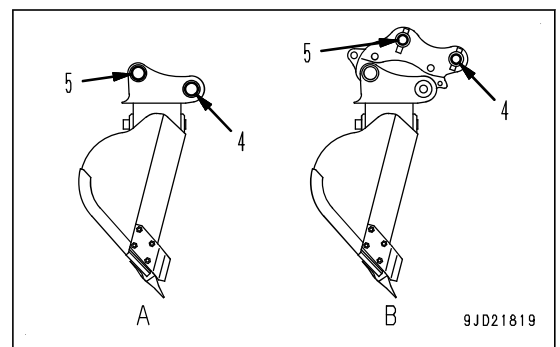

- Tap "Bucket Angle" button.

A check mark is put in the check box of "Bucket Angle Read", and work equipment angle at that posture is saved.

- Tap "Next" button.

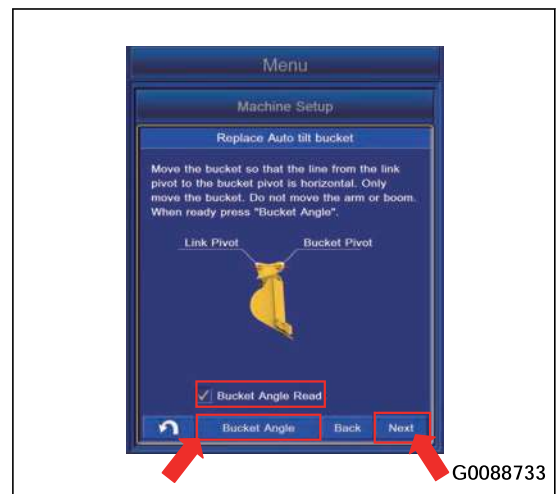

- 14. Use a plumb or a laser level to set the bucket pin (4) and the cutting edge (2) vertically.

Move the bucket only. Do not move the other work equipment (boom, arm) at this time. Also, do not move the bucket in the tilt direction (clockwise or counterclockwise when the bucket is viewed from the operator cab).

(A): When the quick coupler is not installed

(B): When the quick coupler is installed

- 15. Tap "Bucket Angle" button.

A check mark is put in the check box of "Bucket Angle Read", and work equipment angle at that posture is saved.

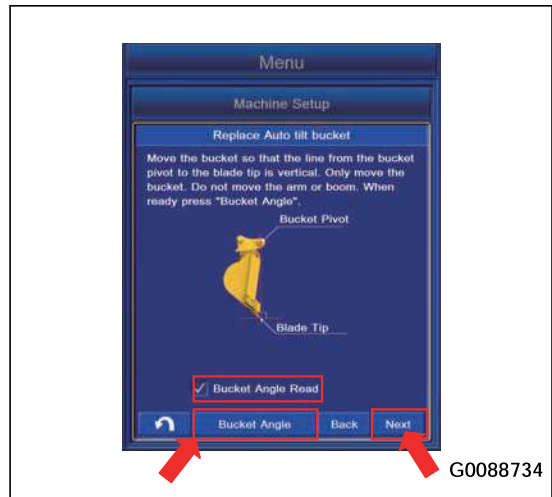
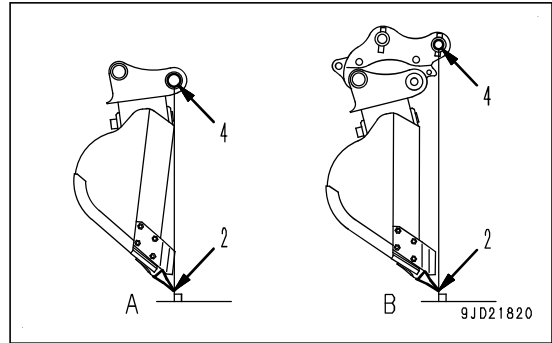

- 16. Tap "Next" button.

REMARK

- Tap "Bucket Angle" button, and a check mark is put in the check box of "Bucket Angle Read", and the work equipment angle is saved. Tap "Bucket Angle" button again, and the check mark in the check box is cleared, and then the work equipment angle can be adjusted again.
- If no check mark is in the check box of "Bucket Angle Read", "Next" button is disabled.

REMARK

Tap "Next" button, and if there is an error in the bucket format set in the bucket file or the entered bucket information, an error screen will be shown.

Tap "Return" button to check that the settings and input are all correct.

Tap the RETURN button, and the screen goes back to the menu screen. At that time, the value which was entered and measured before will be reset.



METHOD FOR CALCULATING AUTOMATIC CALIBRATION AND WRITING PARAMETER VALUE (AUTO TILT BUCKET)

1. Tap Next button.

Automatic calibration is executed.

After the calculation is finished, the screen changes.

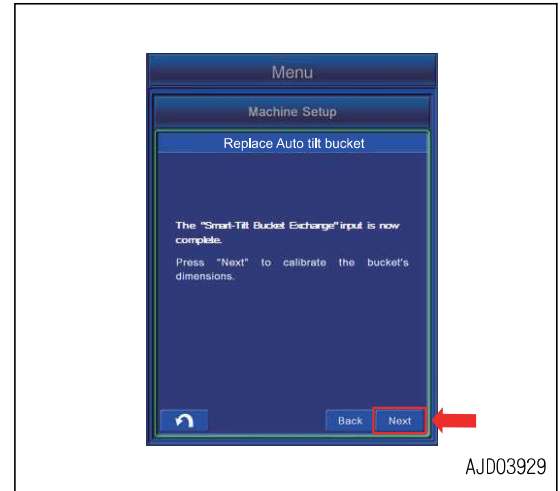

2. Hold down Set button for 0.5 seconds or longer.

The auto tilt bucket parameter obtained by automatic calibration calculation is written in Komatsu controller, and the screen returns to the menu screen.

"Auto tilt bucket exchange" calibration is completed.

If the bucket weight changes largely, bucket weight setting should be executed.

For the bucket weight setting, see BUCKET WEIGHT SETTING.

3. After the setting is completed, turn the starting switch key to OFF position, turn it to ON position again, and restart the control box.

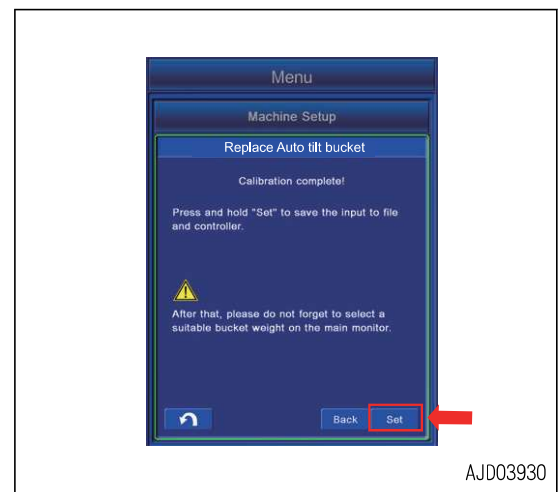

REMARK

When "Auto tilt bucket exchange" calibration is completed, "Auto Tilt Bucket" (ATT/P) and "Auto Tilt Bucket" (ATT/E) will be available on "working mode" screen. If the calibration is performed with the "Working Mode" screen opened on the machine monitor, return to the standard screen first, then open the "Working Mode" screen again. The screen is updated.

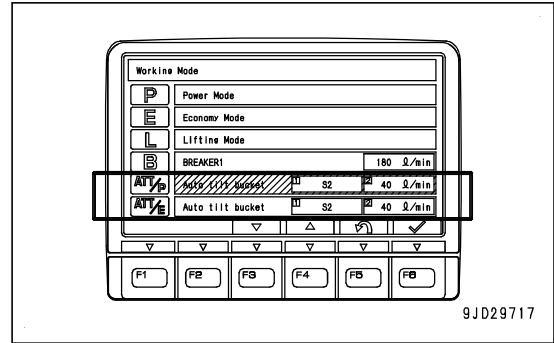

9JD29717

4. Tap Next button.

If automatic calibration calculation fails, error screen is displayed.

In this case, an input value may be wrong or the accuracy of the digital angle gauge may be poor.

Tap Back button, and check back the input result according to the following procedure.

- 1) Check that the inputs are correct.
Input the correct value again if there is anything wrong.
- 2) Check that the accuracy of digital angle gauge used is within 0.2 °.
Use another angle gauge if the accuracy of digital angle gauge used is not within 0.2 °.

- 3) Check that the calibration of digital angle gauge has been performed.
If the calibration of angle gauge is not performed, perform it.
- 4) Check that the digital angle gauge is set parallel to the bucket edge line.
If it is not parallel, set the digital angle gauge again.
- 5) Check that the tilt axis is horizontal.
If the tilt axis is not horizontal, adjust it again.

- 6) Check that the automatic calibration calculation has finished.
If it has not finished, it may have failed in other procedure. Perform the calibration again from the beginning.
If it does not yet finish, ask your Komatsu distributor for inspection.

Tap RETURN button, and the screen returns to the menu screen. At that time, the value which has been input and measured will be reset.

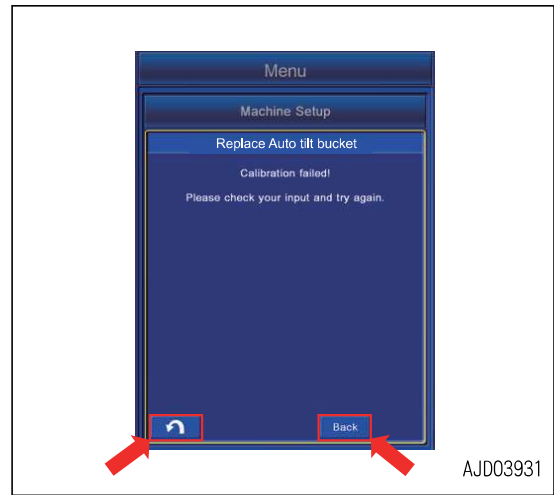

AJD03931

REMARK

The auto tilt bucket and arm connected with an yellow line are displayed on the working screen of control box when "Auto tilt bucket exchange" calibration is completed.



AJD01901